

ACERBOX

BY SPACE AGE ELECTRONICS



BCA Battery Cabinets

When your professional installation requires battery backup storage compliant with NFPA 72 (1-5.2.9), the BCA is your ideal solution.

With the ability to be securely wall mounted, these cabinets allow easy access to your batteries for quick maintenance while reducing the risk of unnecessary power drain, interference or degeneration.

SPECIFICATIONS

The BCA Battery Cabinet Accessory is constructed of 16 gauge cold rolled steel and finished with a complete interior and exterior durable red or black powder coat. The front cover features a full length stainless steel piano hinge and includes a CAT 30 keyed door lock. Overall dimensions measure 22" wide by 10" high by 8 1/2" deep. Four 1/2" and 3/4" EMT conduit knockouts are located on the sides and back. The battery cabinet meets NFPA 72 (1-5.2.9) and National Electric Code requirements. Batteries not included.

AGENCY APPROVALS

UOXX.S2580 UL Listed Control Unit Accessories

CUSTOM COLORS AND BRANDING AVAILABLE



FEATURES

- 16 gauge cold rolled steel construction
- Dimensions are 22" wide x 10" high x 8 1/2" deep
- CAT 30 keyed door lock (custom locks available)
- Four 1/2" and 3/4" EMT conduit knockouts located on both sides and back
- Vented sides to reduce corrosion
- Wall mounting holes
- Accommodates 2 batteries up to 75Ah



DIMENSIONS

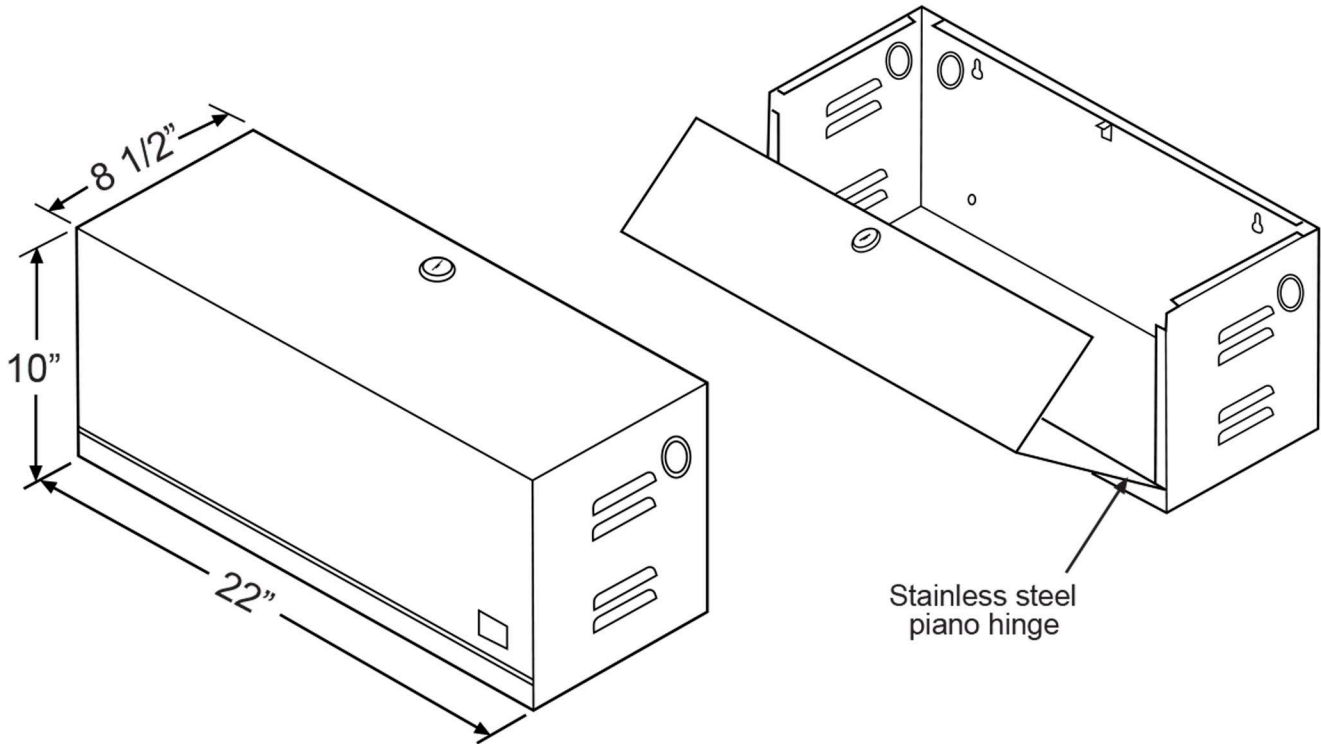

ORDERING INFORMATION

P/N# SSU00500

BCA Battery Cabinet - Red

P/N# SSU00501

BCA Battery Cabinet - Black

P/N# SSU-SC-111/T

Gator Relays Fuse Board Module (can be field-installed as optional fuse block)

